

Mechanical Dimensions – Smart (8 pin socket)

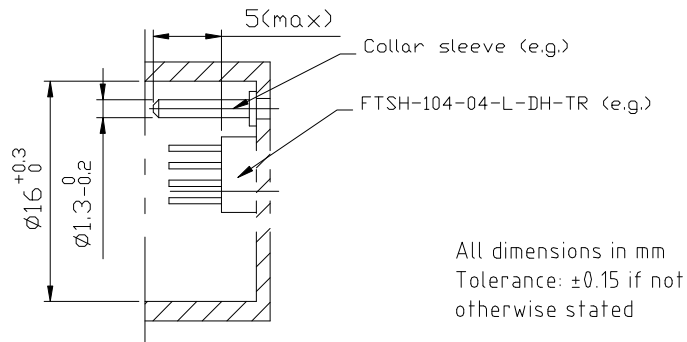
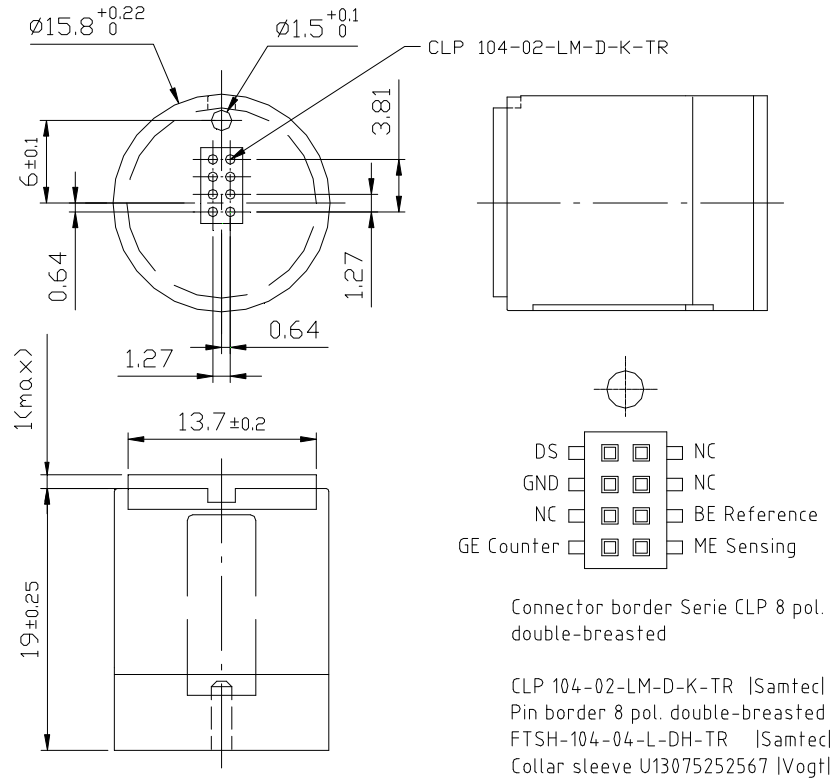

Material: ABS plastics or PPO; gold plated pins

Note:

Please note, that the reference electrode is not in use at all 2-electrode Sensoric sensor versions.
 Part number and further technical details are available at our website.